

DC100

Weight	8 kg
Nominal power	100 kW
Nominal input voltage	350 V
Nominal input current	300 A
Nominal output current (phase)	300 Arms
Max switching frequency	50 kHz
DC bus capacitance	180 μ F
Short circuit protection	YES
Vehicle system power	12 V
Cooling	Liquid
CAN interface	YES
RS-232 interface	YES

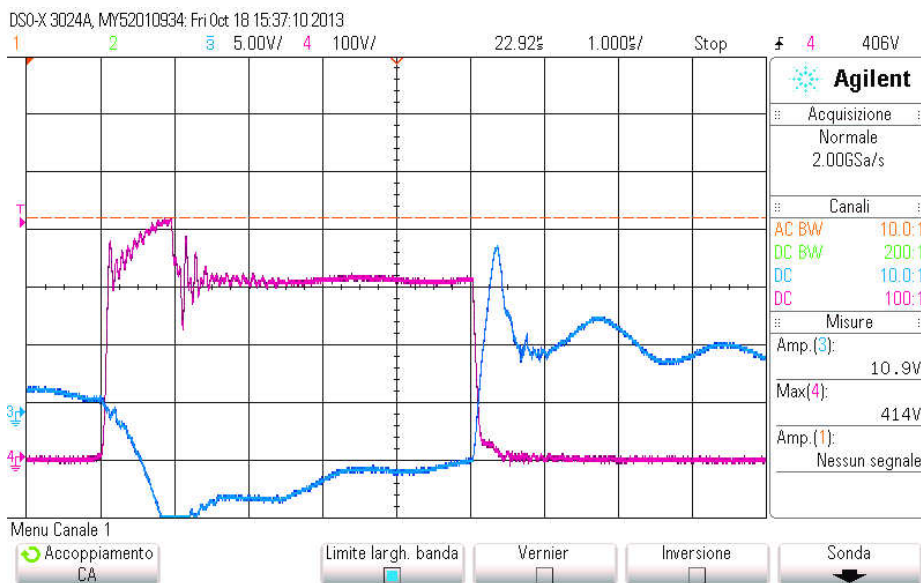

Mavel DC100

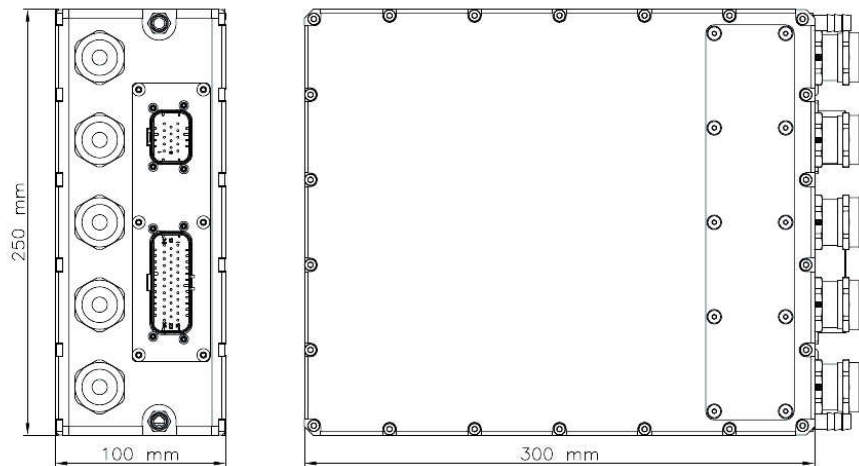
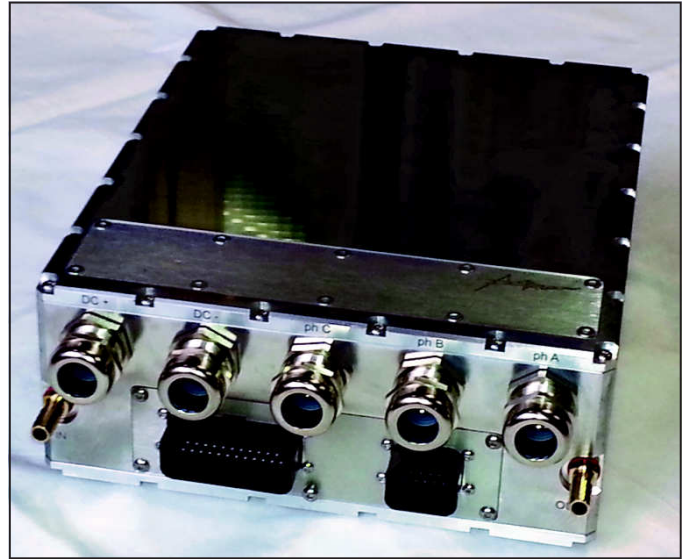

www.mavelpowertrain.com
info@mavelpowertrain.com

